



KEY FEATURES

- Engine: Deutz TCD 7.8
- Boom suspension system
- Locking front axle
- Lift and return to dig kick-out
- Transmission neutralizer
- GPS
- Single joystick control
- Preplumbed for quick coupler
- Reversible fan
- Rear view camera

Gross Power

262 hp / 195 kW

Bucket Capacity

4.0 yd³ / 3.0 m³

Operating Weight

40,124 lb / 18 500 kg

Tipping Load

28,660 lb / 14 500 kg

SW405 Dimensions & Specifications

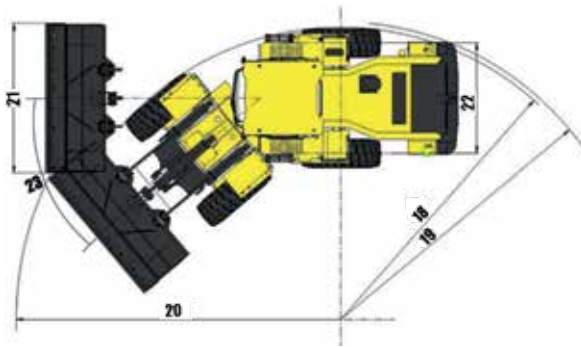
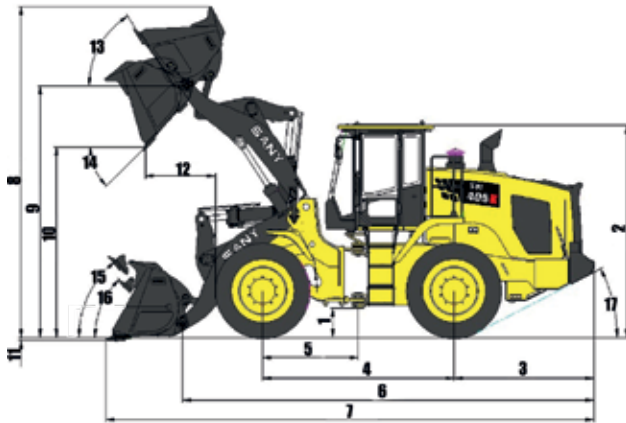

OVERALL DIMENSIONS

	Standard	Metric
1 Height to Axle Centerline	17.32"	440 mm
2 Height to Top of Cab	138.86"	3527 mm
3 Center Line or Rear Axle to Edge of Counterweight	91.73"	2330 mm
4 Wheelbase	125.98"	3200 mm
5 Center Line of Rear Axle to Hitch	63"	1600 mm
6 Shipping Length without Attachment	270.16"	6862 mm
7 Shipping Length with Bucket	320.55"	8142 mm
8 Max. Dump Height	214.21"	5441 mm
9 Hinge Pin Height at Max. Lift	162.72"	4133 mm
10 Dump Clearance at Max. Lift	122.76"	3118 mm
11 The lowest Dump to the Ground	2.2"	56 mm
12 Reach at Max. Lift and 45° Discharge	44.88"	1140 mm
13 Rack Back at Max. Lift		58°
14 Dump Angle at Max. Lift and Dump		45°
15 Rack Back at Carry Height		51°
16 Rack Back at Ground		45°
17 Tail Angle to the rear wheel		27°
18 Clearance Circle to Outside of Tires	228.35"	5800 mm
19 Clearance Circle to Counterweight	232.72"	5911 mm
20 Max. Circle	254.17"	6456 mm
21 Width of the Bucket	117.13"	2975 mm
22 Width	86.61"	2200 mm
23 Articulation Angle		+/- 40°

MACHINE PARAMETERS

Engine	Engine Model	Deutz TCD7.8
	Max Gross Power	262 hp
	Max Gross Torque	962 ft lbs
	Displacement	7.8 ltr

Operating	Bucket Capacity	4.0 cubic yards
	Tipping Load Straight	31,967 lbs
	Tipping Load @ full Turn	28,881 lbs
	Clearance (full lift 45° dump)	10' 2"
	Reach (full lift 45° dump)	3' 10"

Weight	Operating Weight	40,786 lbs
--------	------------------	------------

Hydraulic System	Pump Model	Implement - Kawasaki
	Max Flow	81 GPM
	Max Pressure	3916 PSI

Hydraulic Cycle Times	Raise	5.4 sec
	Dump	1.9 sec
	Float Down	3.3 sec
	Total Cycle Time	10.6 sec

Service Capacities	Fuel Tank	85 gal
	Cooling System	5.25 gal
	Engine Crankcase	6 gal
	Transmission	4.7 gal
	Front Axle	5 gal
	Rear Axle	5 gal
	Hydraulic Tank	31 gal
DEF Tank	10.5 gal	

Transmission	Shift Modes	Automatic, Manual, KD
	Forward Gear 1	4.4 mph
	Forward Gear 2	8 mph
	Forward Gear 3	16 mph
	Forward Gear 4	25 mph
	Reverse Gear 1	4.4 mph
	Reverse Gear 2	8 mph
Reverse Gear 3	16 mph	

Power Train	Front Axle	Fixed
	Traction Aid	Manual Differential Lock
	Rear Axle	Oscillating
	Traction Aid	Open differential
	Service Brakes	Wet Disk
Parking Brake	SAHR Disk Brake	

SANY America Inc.

318 Cooper Circle | Peachtree City, GA 30269
T: 678-251-2810 | F: 770-632-7820

www.sanyamerica.com

